



2069

PATENTED

Water full bore ball valve with meter's entrance, thread female/nut, check valve incorporated, technopolymer handle, extractable and replaceable security lock and ball with automatic rinse system.



Technical specifications

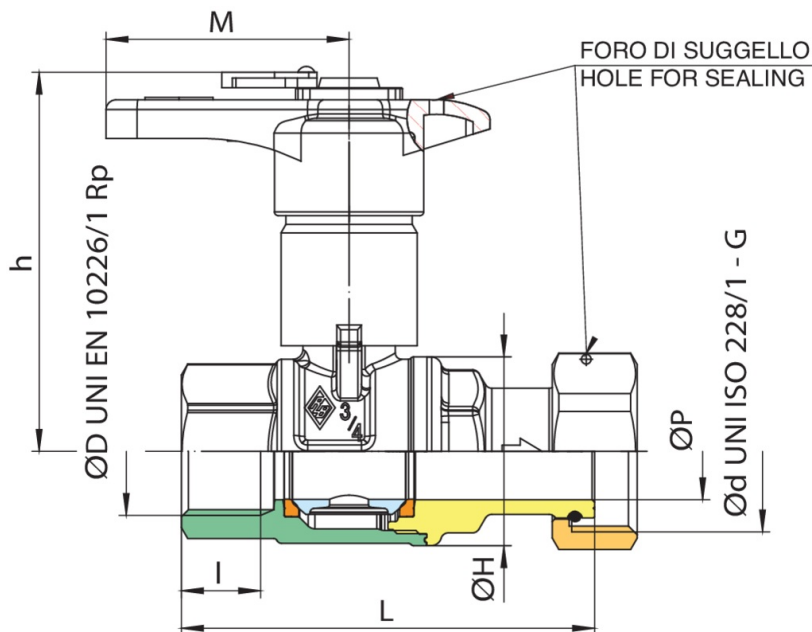

Applications



DRINKING
WATER



MULTIUTILITY ONLY