

BUBBLE-SFER

5811



Water full bore ball valve with meter's exit, thread female/nut, **large** check valve incorporated, pressure measurement connection aluminium butterfly handle and ball with automatic rinse system.

NEW



Technical specifications

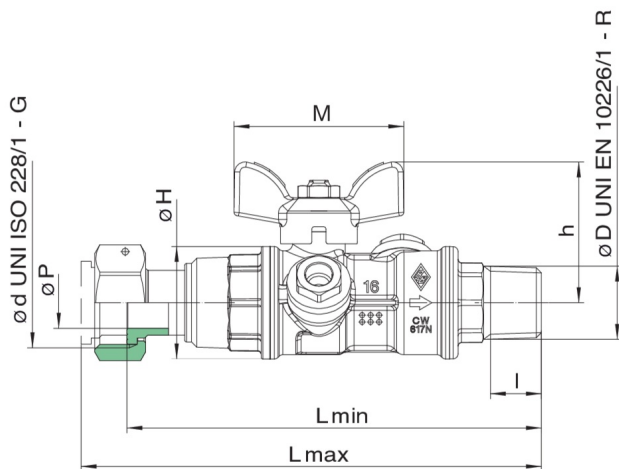

| POSITION | PART NAME | MATERIAL | N.° PIECES |
|----------|-------------------------|--------------------------------------|------------|
| 1 | BODY | BRASS CW617N UNI EN 12420 | 1 |
| 2 | END CONNECTION | BRASS CW617N UNI EN 12420 | 1 |
| 3 | END CONNECTION | BRASS CW617 UNI EN 12420 | 1 |
| 4 | BALL | BRASS CW617N UNI EN 12420 | 1 |
| 5 | STEM | BRASS CW614N UNI EN12164-UNI EN12168 | 1 |
| 6 | PACKING GLAND | BRASS CW614N UNI EN12164-UNI EN12168 | 1 |
| 7 | MALE UNION TALE | BRASS CW614N UNI EN12164-UNI EN12168 | 1 |
| 8 | T-HANDLE | ALUMINIUM EN-AC 46100 EN 1706 | 1 |
| 9 | BALL SEAT | PTFE | 2 |
| 10 | STEM SEAL/THRUST WASHER | PTFE | 2 |
| 11 | CAP | BRASS CW614N UNI EN12164-UNI EN12168 | 2 |
| 12 | O-RING | NBR | 1 |
| 13 | O-RING | NBR | 2 |
| 14 | O-RING | NBR | 2 |
| 15 | NUT | BRASS CW617N UNI EN 12420 | 1 |
| 16 | NUT | STEEL | 2 |
| 17 | CHECK VALVE | POM | 1 |

| ØD X ØD | DN | BOX | MASTER BOX | CODE | ØP | I | ØH | L MIN | L MAX | H | M | KV | PN | KG |
|-------------|----|-----|------------|------------|----|----|----|-------|-------|----|----|----|----|------|
| 1/2" x 3/4" | 15 | 10 | 40 | 5811260000 | 15 | 15 | 33 | 122 | 135,5 | 41 | 50 | 9 | 64 | 0,45 |

Applications



DRINKING
WATER



MULTIUTILITY ONLY